

# Deciphering the complexity of Gamma-ray Bursts: evidence for Self Organized Criticality?

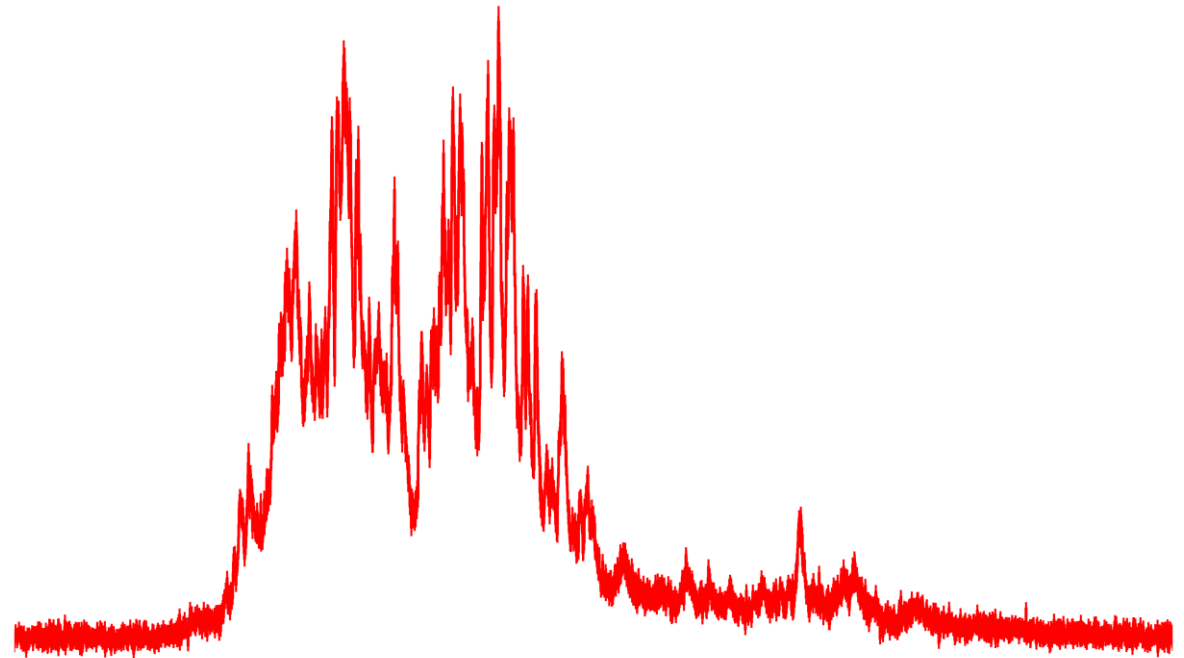

**Romain Maccary**

romain.maccary@edu.unife.it



# Gamma-ray bursts (GRBs) in a nutshell

---

GRBs are the brightest explosions on stellar scale

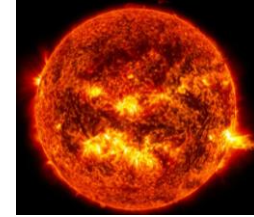

$L \sim 10^{51-54}$  erg/s  
can be up to a  $M_{\odot}$   
in few s

# Gamma-ray bursts (GRBs) in a nutshell

GRBs are the brightest explosions on stellar scale

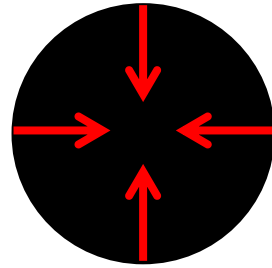

Collapsar

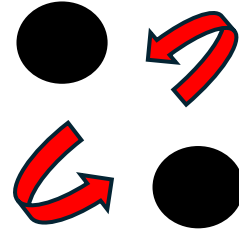

Merger

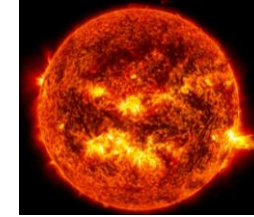

$L \sim 10^{51-54}$  erg/s  
can be up to a  $M_{\odot}$   
in few s

# Gamma-ray bursts (GRBs) in a nutshell

GRBs are the brightest explosions on stellar scale

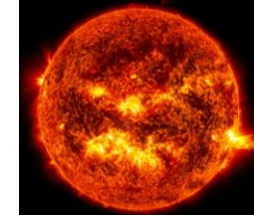

$L \sim 10^{51-54}$  erg/s  
can be up to a  $M_{\odot}$   
in few s

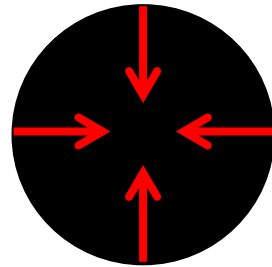

Collapsar

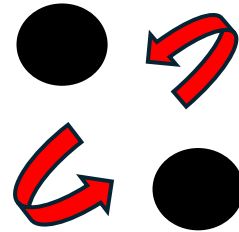

Merger



Hyper-accreting black hole

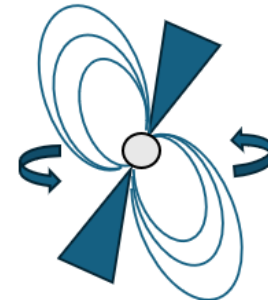
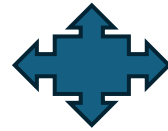

ms-magnetar

# Gamma-ray bursts (GRBs) in a nutshell

GRBs are the brightest explosions on stellar scale

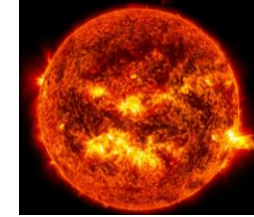

$L \sim 10^{51-54}$  erg/s  
can be up to a  $M_{\odot}$   
in few s

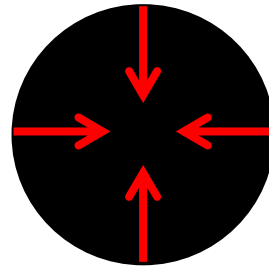

Collapsar

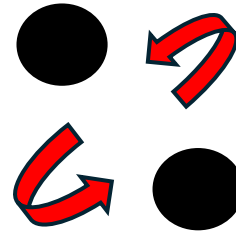

Merger



Hyper-accreting black hole

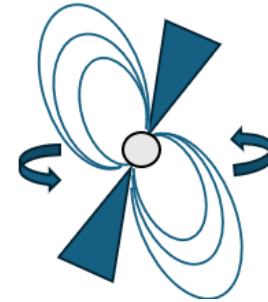

ms-magnetar

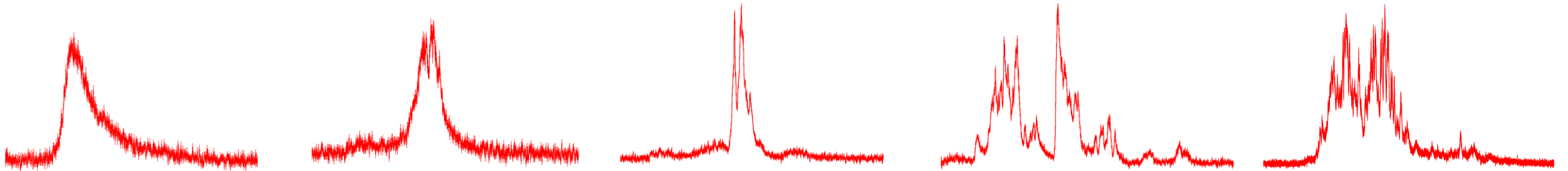

# Gamma-ray bursts (GRBs) in a nutshell

GRBs are the brightest explosions on stellar scale

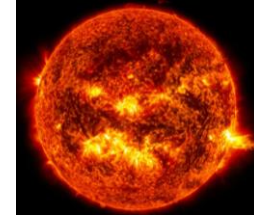

$L \sim 10^{51-54}$  erg/s  
can be up to a  $M_{\odot}$   
in few s

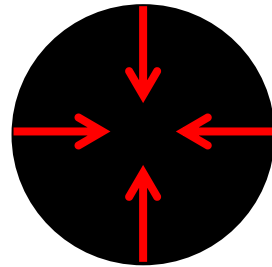

Collapsar

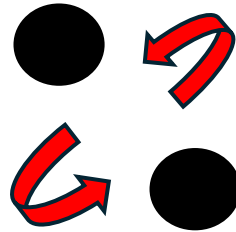

Merger



Hyper-accreting black hole

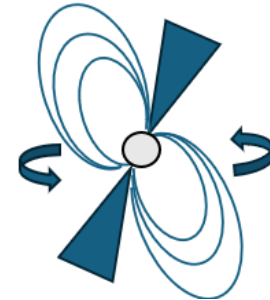
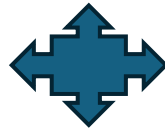

ms-magnetar

Huge diversity:  
stochastic or deterministic behaviour?

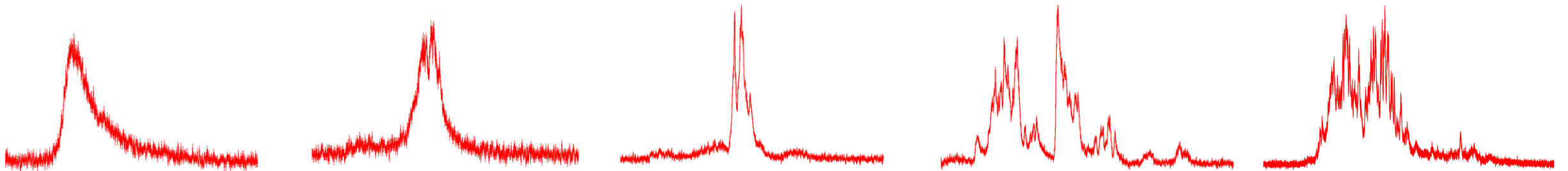

# Self Organized Criticality (SOC) in a nutshell

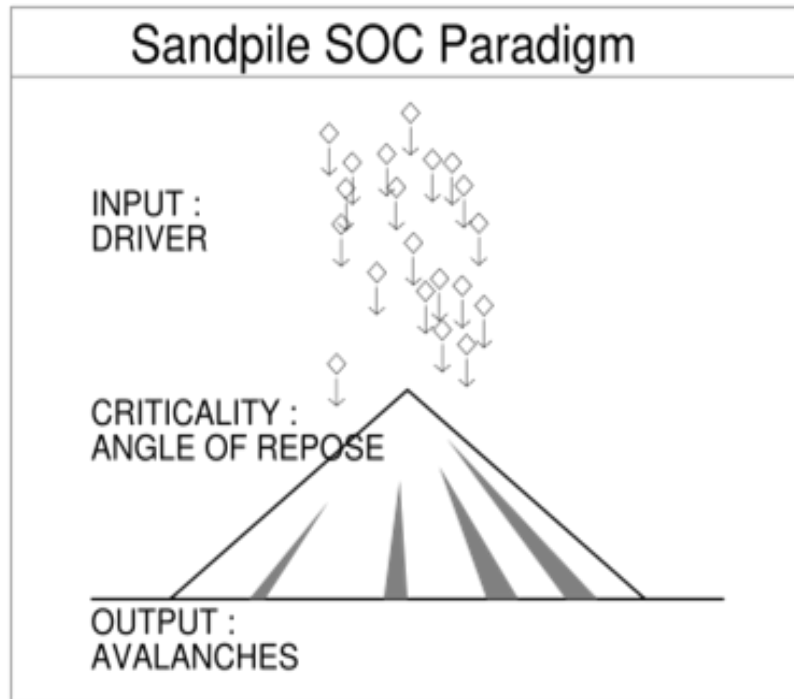

BTW (Bak-Tao-Wiesenfeld) sandpile model

# Self Organized Criticality (SOC) in a nutshell

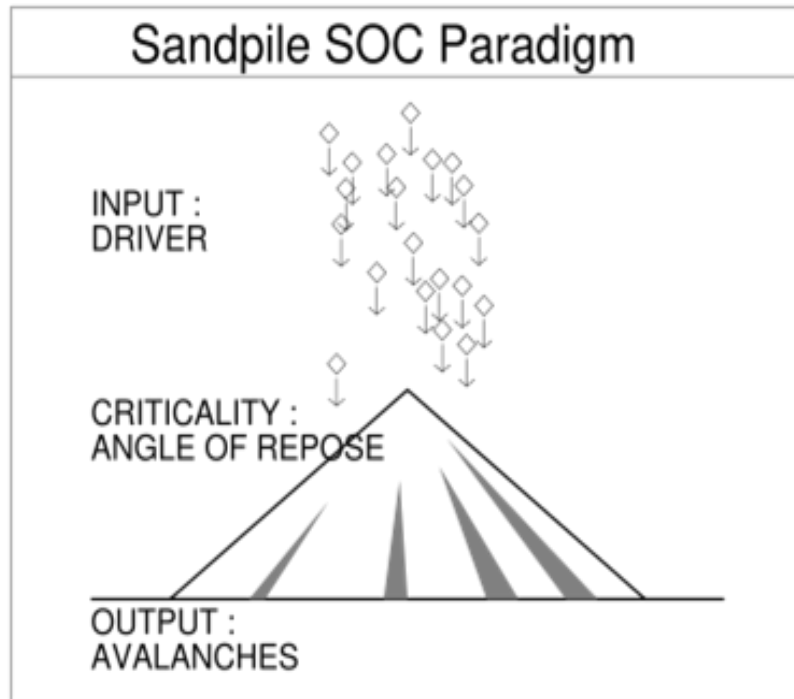
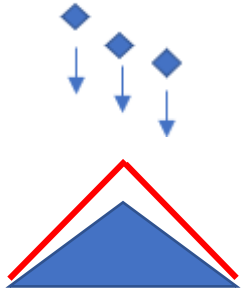

BTW (Bak-Tao-Wiesenfeld) sandpile model

# Self Organized Criticality (SOC) in a nutshell

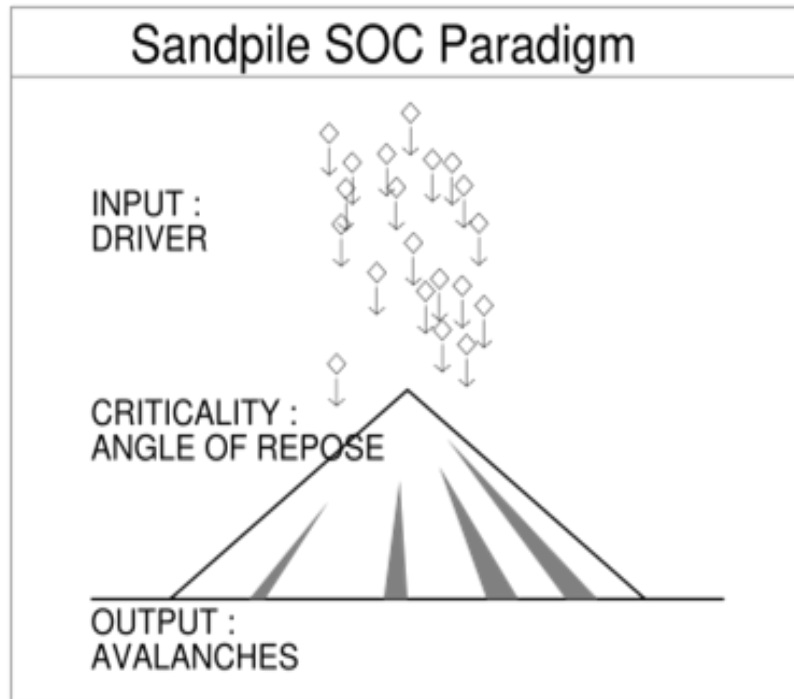
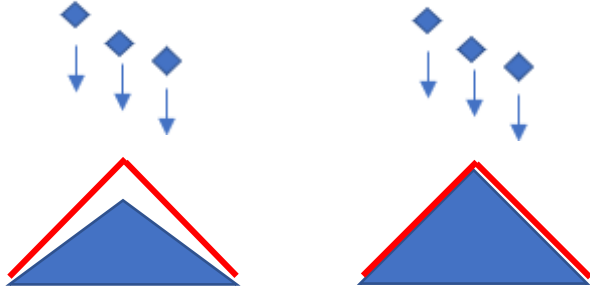

BTW (Bak-Tao-Wiesenfeld) sandpile model

# Self Organized Criticality (SOC) in a nutshell

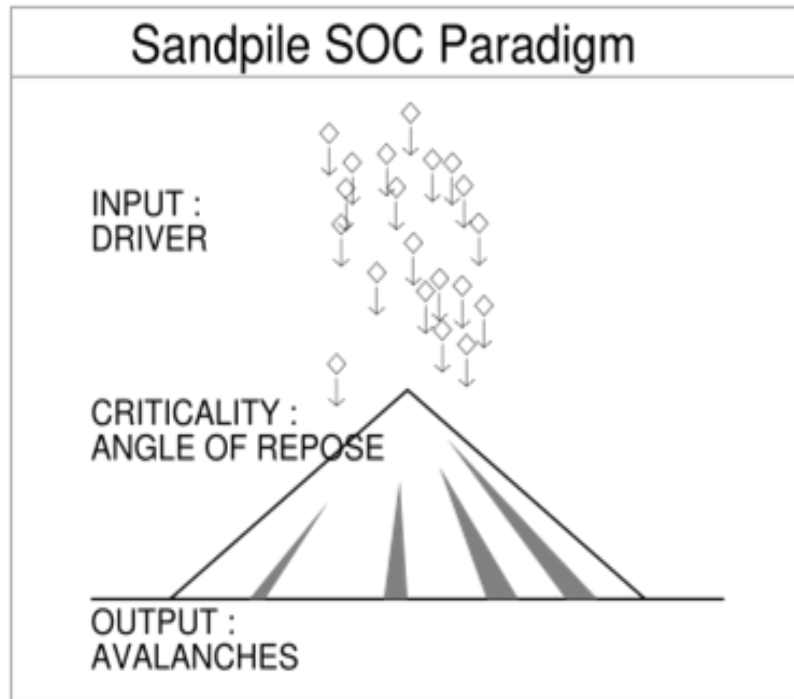
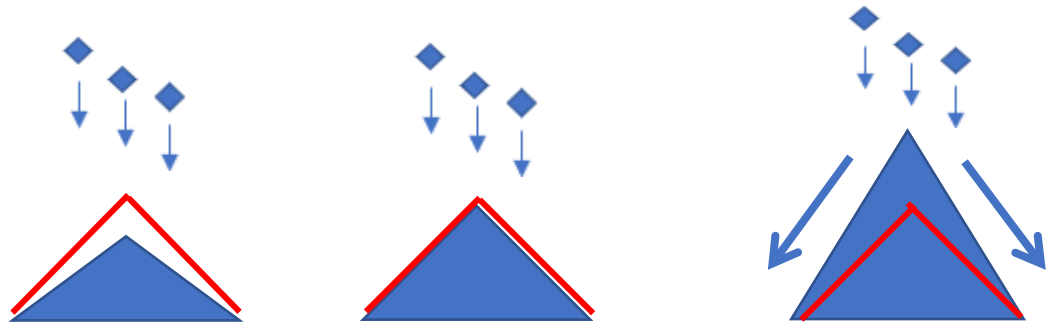

BTW (Bak-Tao-Wiesenfeld) sandpile model

# Self Organized Criticality (SOC) in a nutshell

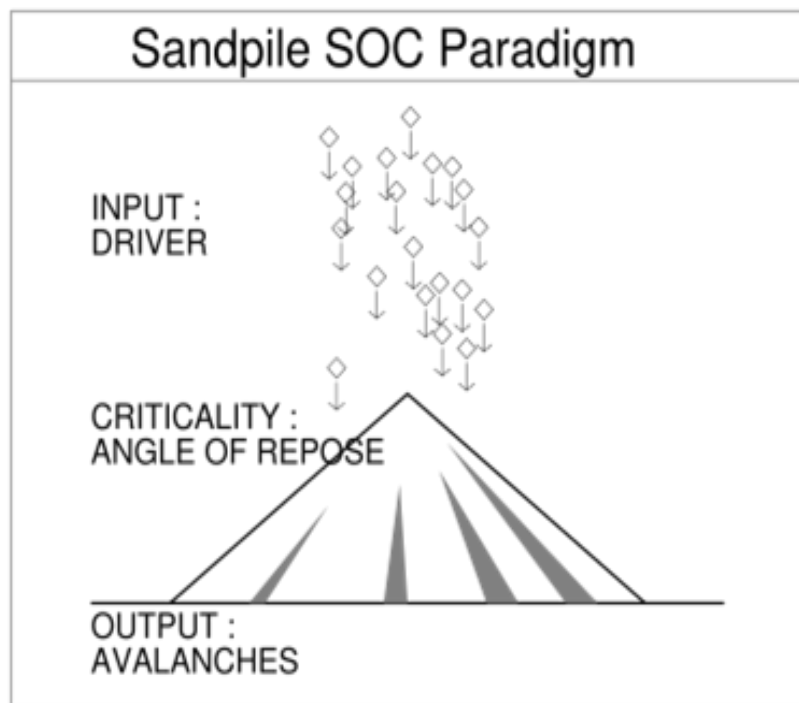
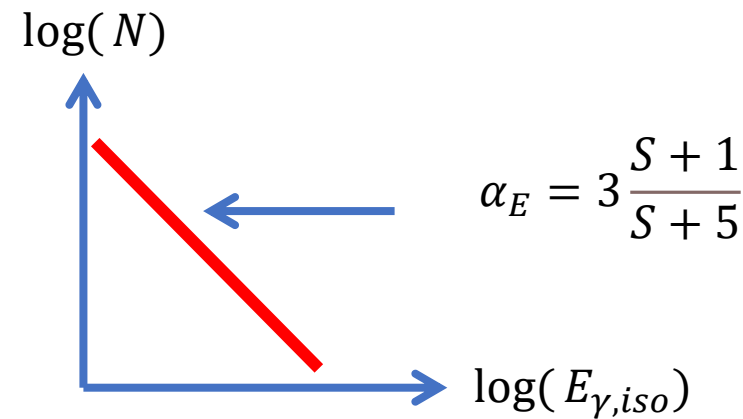
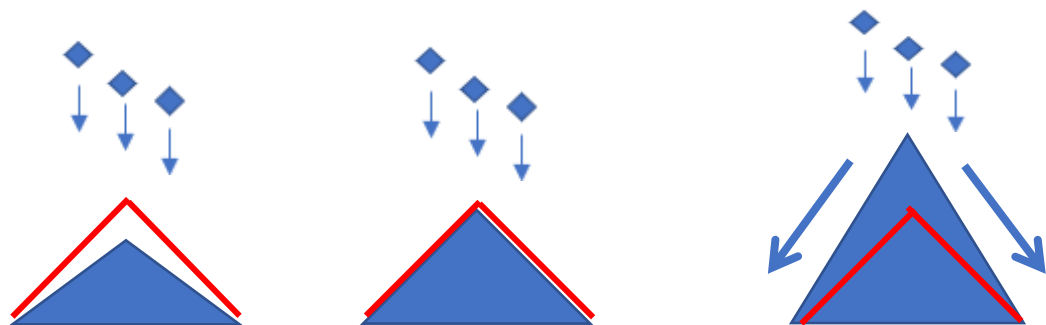

BTW (Bak-Tao-Wiesenfeld) sandpile model

# Self Organized Criticality (SOC) in a nutshell

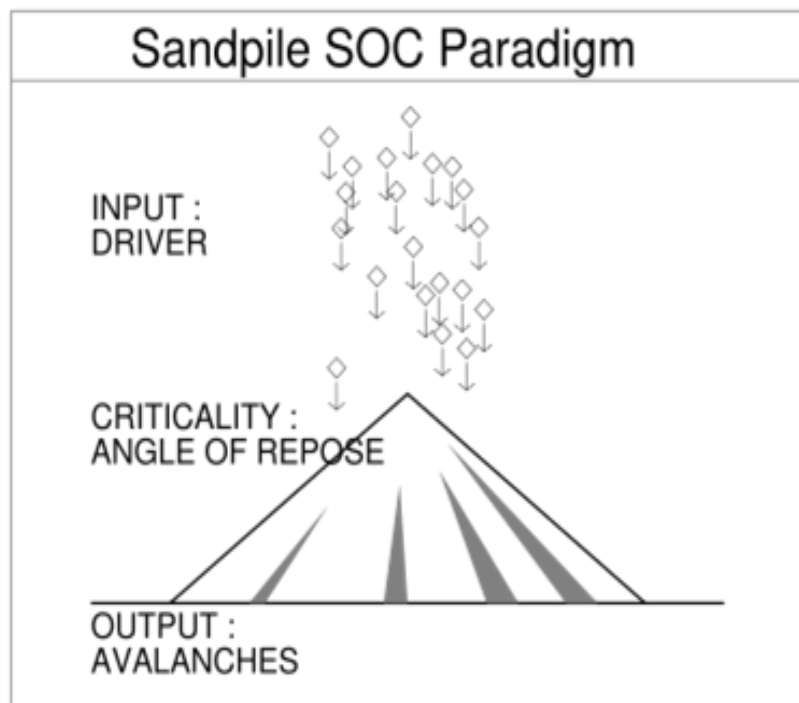
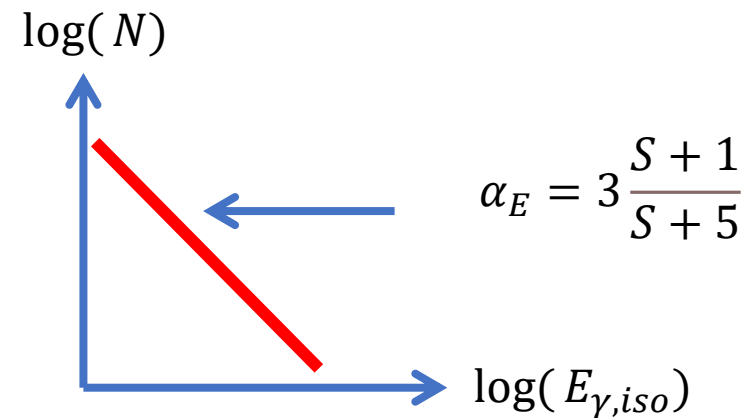
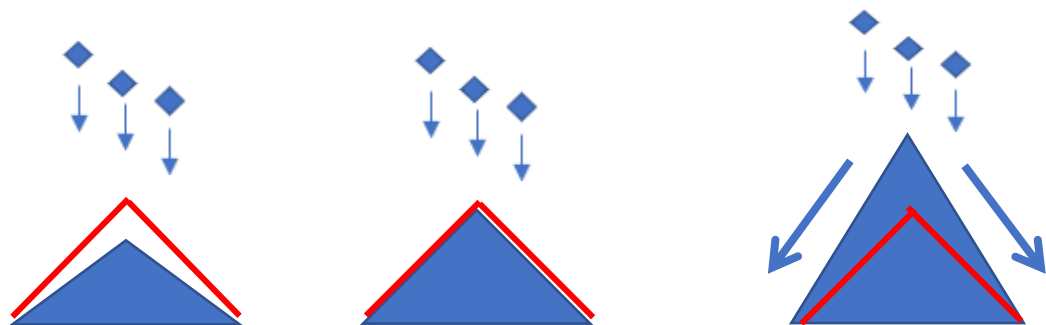

$\alpha_E$	$S$
1	1
9/7	2
3/2	3

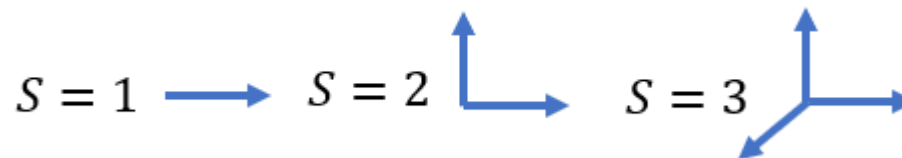

BTW (Bak-Tao-Wiesenfeld) sandpile model

# SOC in astrophysics

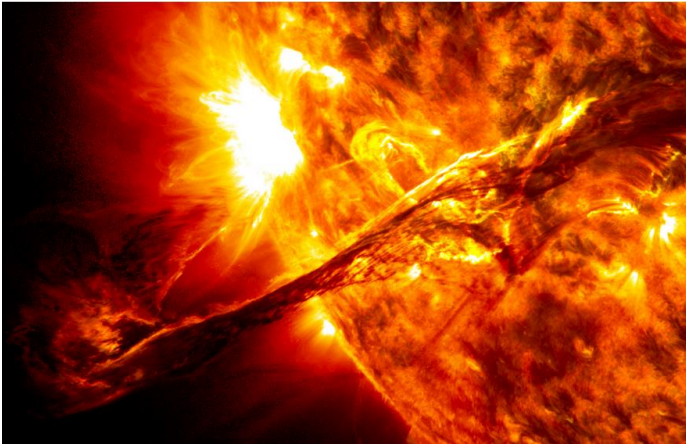

Solar flare  $S=3$

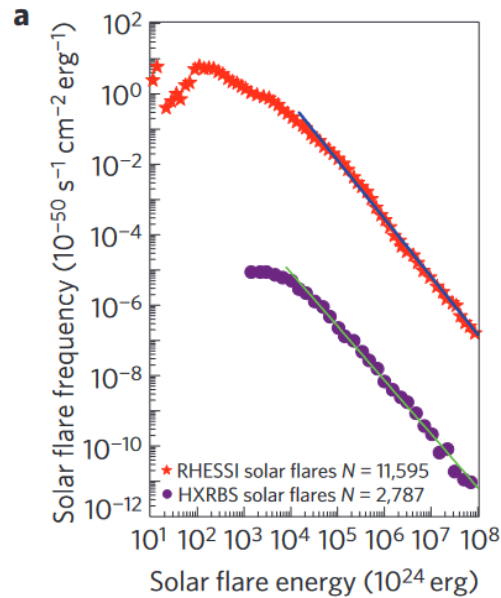

Wang and Dai, 2013

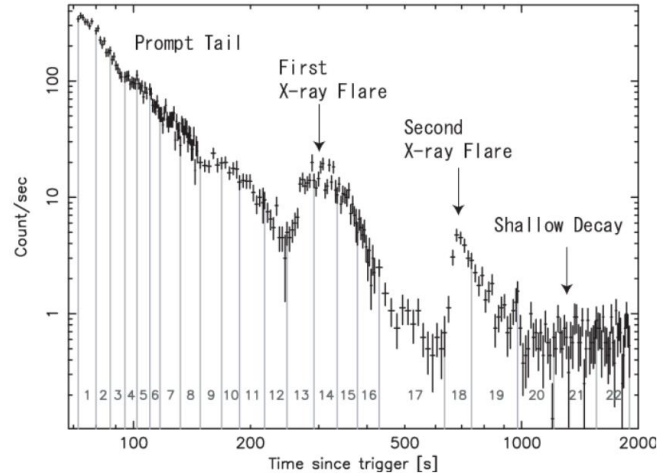

GRB X-ray flare  $S=1$  ?

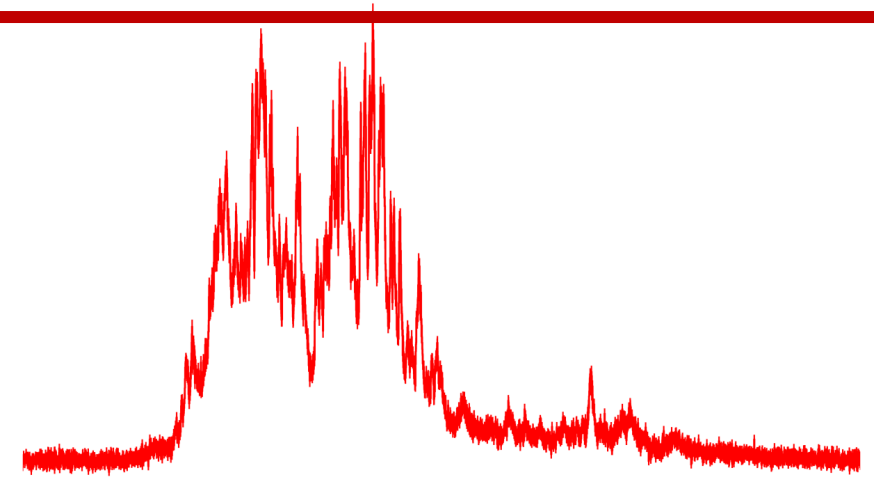
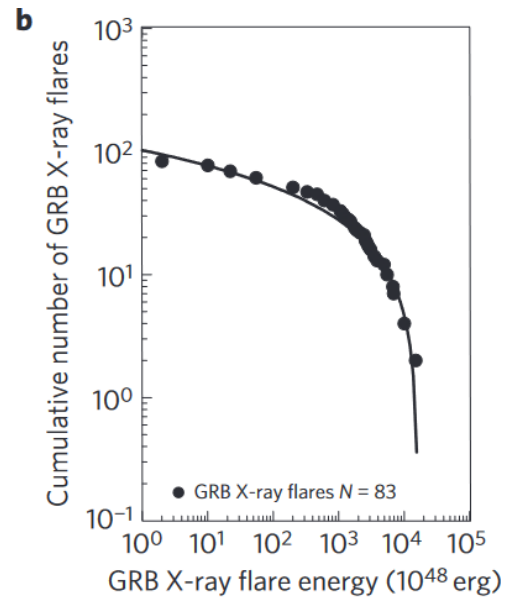

GRB prompt emission  $S=3$  ?

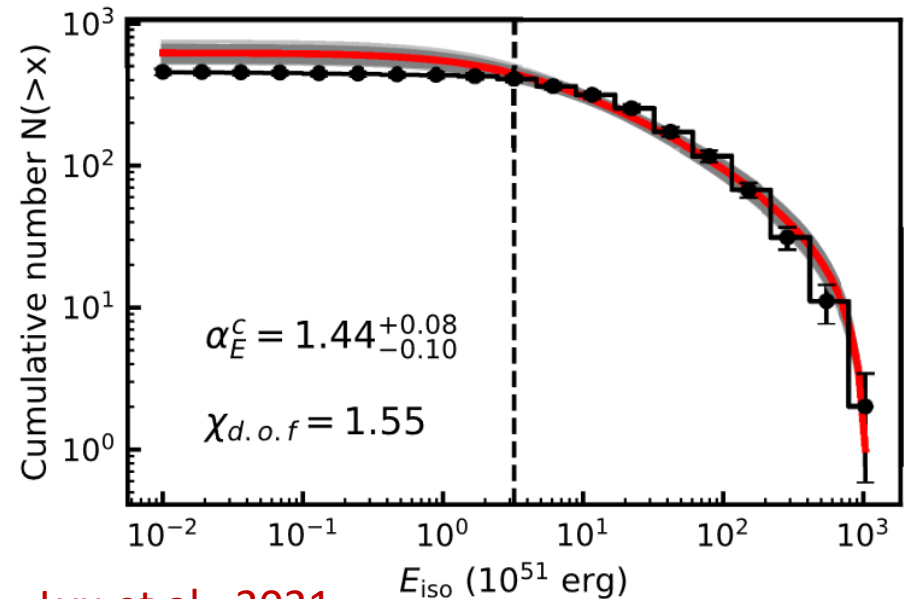

Lyu et al., 2021

# Fermi/GBM

**Fermi**  
**Gamma-ray Large Area**  
**Space Telescope**  
**(2008-)**

**LAT**  
**Large Area Telescope**  
**(20 MeV - 300 GeV)**

**GBM**  
**Gamma-ray Burst**  
**Monitor (8-40 MeV)**

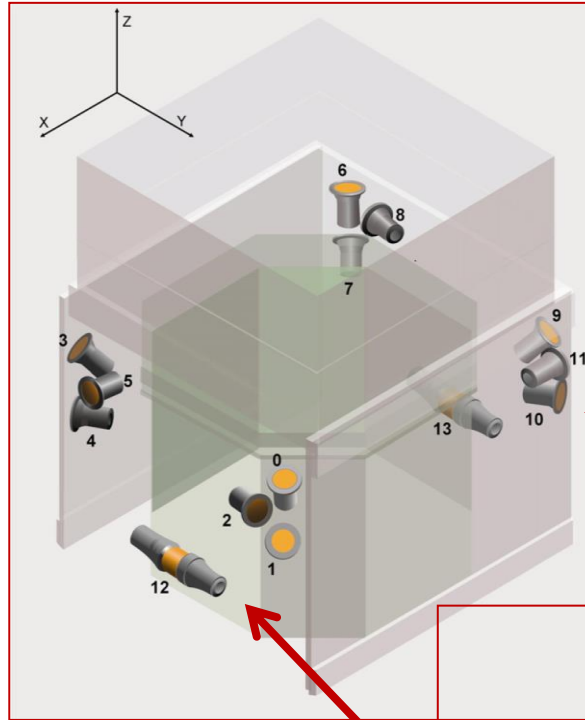

**12 NaI(Tl) detectors**  
**(8 - 1000 keV)**

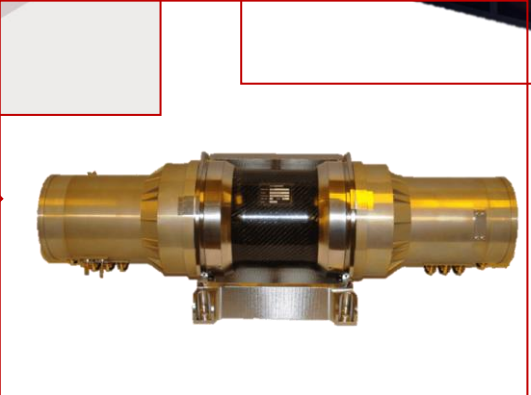
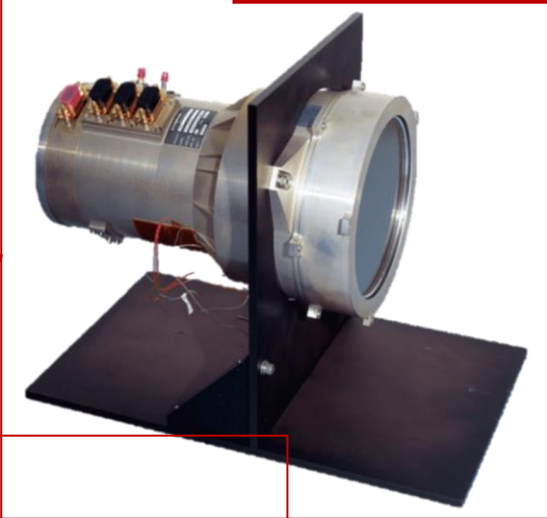

**2 BGO detectors**  
**(200 keV - 40 MeV)**

# Data analysis scheme

142 GRBs with known  $z$   
Lightcurve with  
background

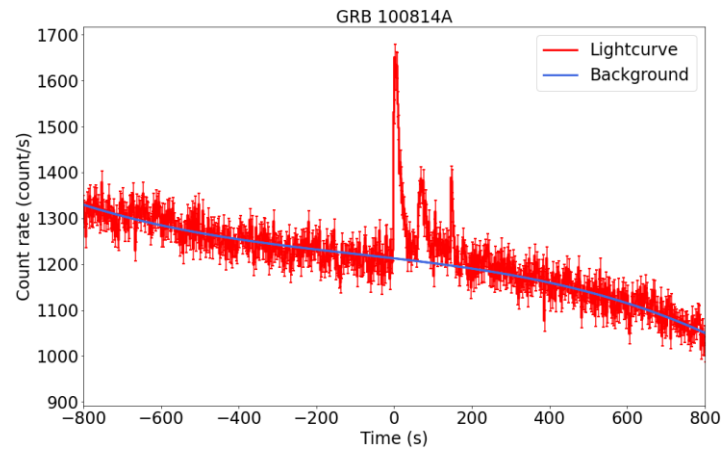

# Data analysis scheme

142 GRBs with known  $z$   
Lightcurve with  
background

Background  
interpolation  
→

Background subtracted  
lightcurve

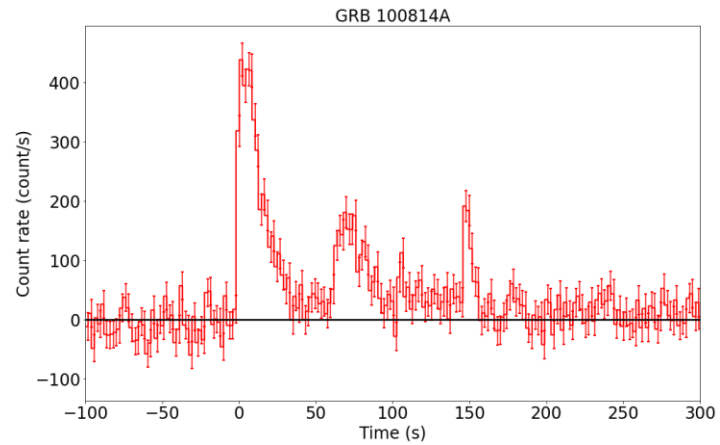
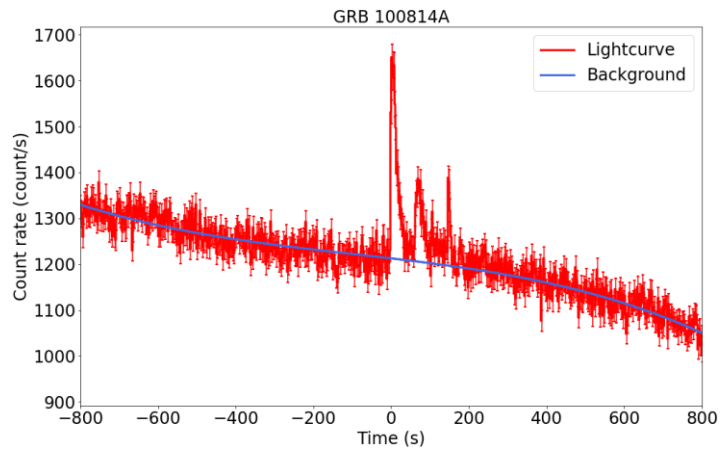

# Data analysis scheme

142 GRBs with known  $z$   
Lightcurve with  
background

Background  
interpolation  
→

Background subtracted  
lightcurve

MEPSA  
→

Identification of peak  
times and peak count rates

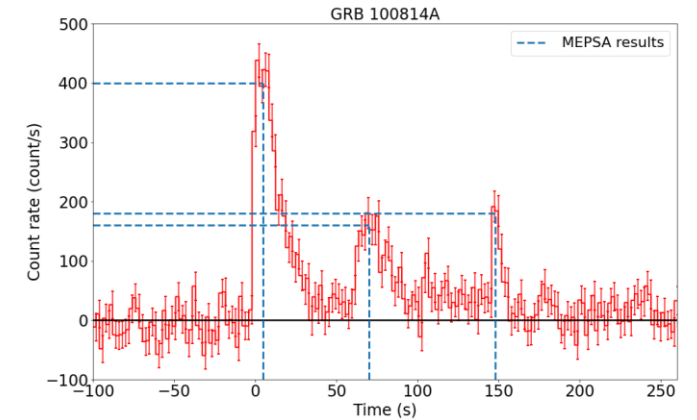
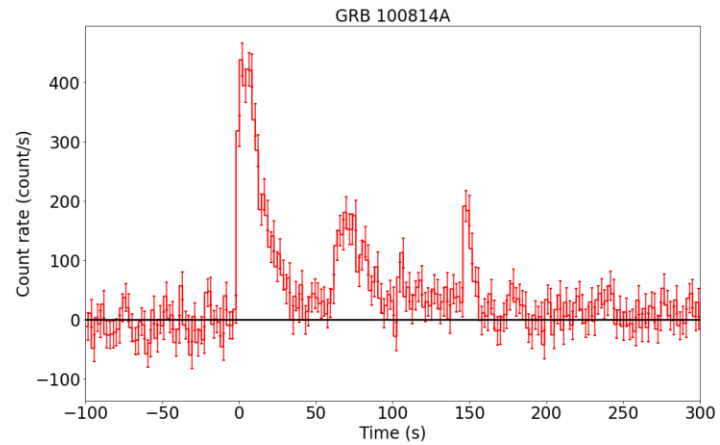
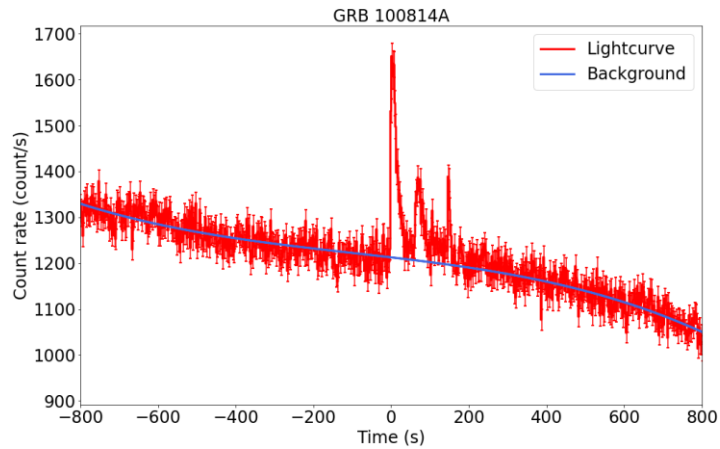

# Data analysis scheme

142 GRBs with known  $z$   
Lightcurve with background

Background interpolation

Background subtracted lightcurve

MEPSA

Identification of peak times and peak count rates

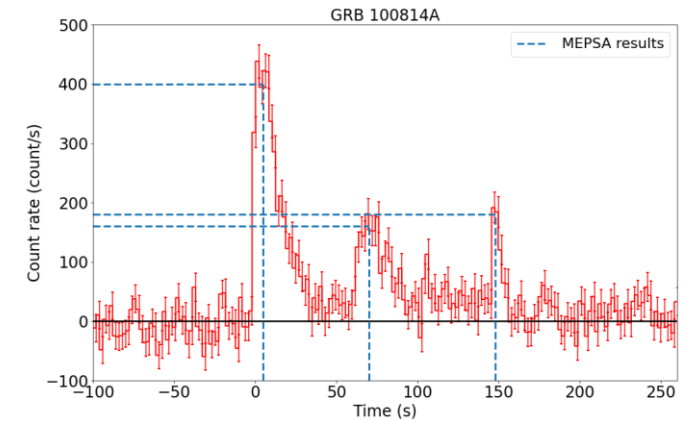
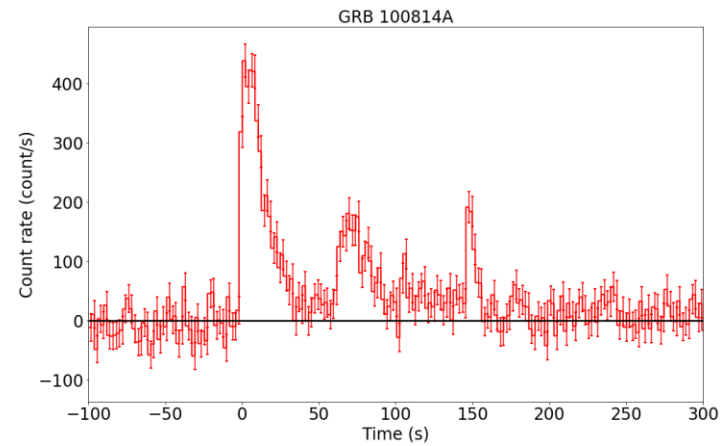
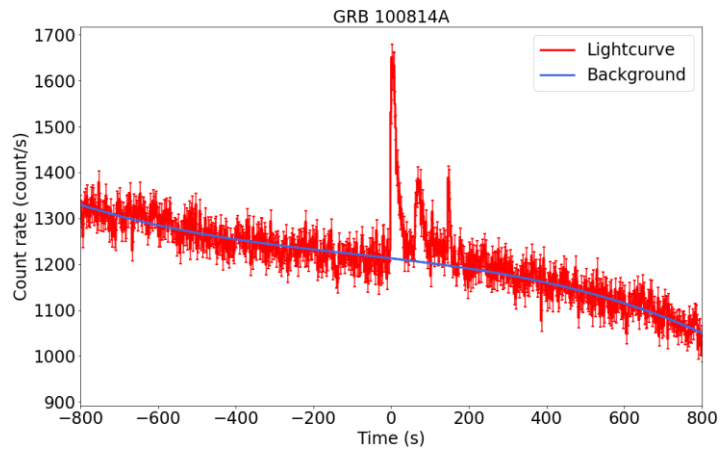

Lightcurve modelled by a superposition of FRED (Fast Rise Exponential Decay) functions

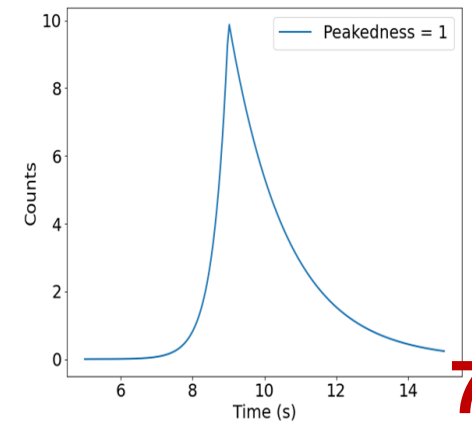

# Data analysis scheme

142 GRBs with known  $z$   
Lightcurve with background

Background interpolation

Background subtracted lightcurve

MEPSA

Identification of peak times and peak count rates

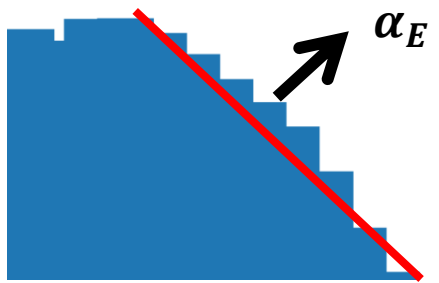
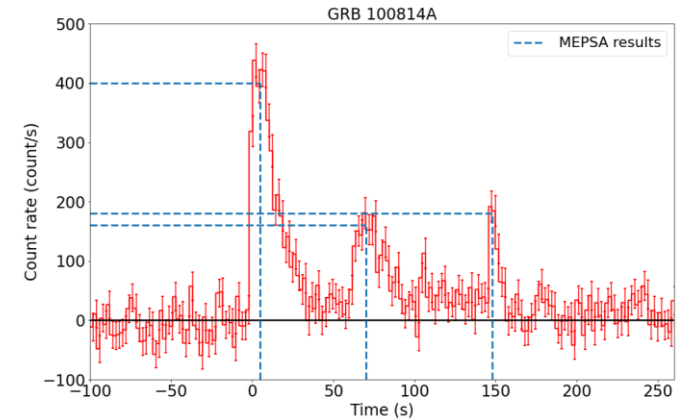
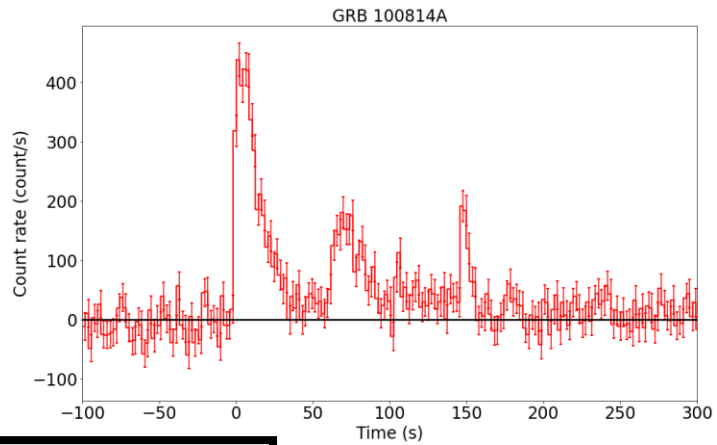
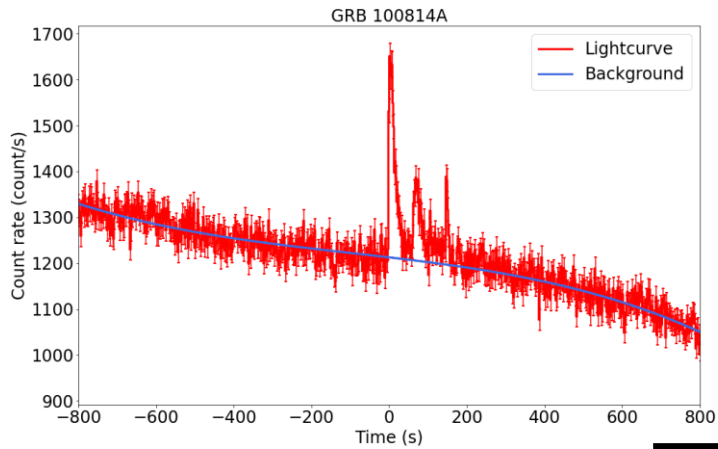

Fluence in the 8-1000 keV band

$E_{\gamma,iso}$

Redshift

Lightcurve modelled by a superposition of FRED (Fast Rise Exponential Decay) functions

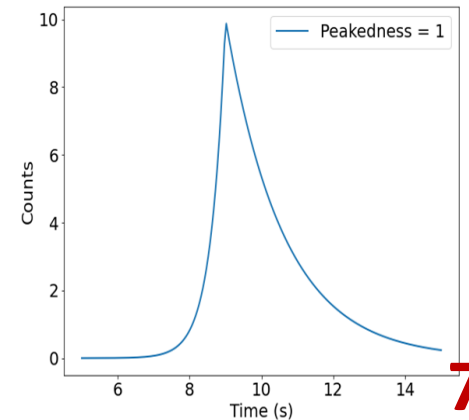

# Selection effects

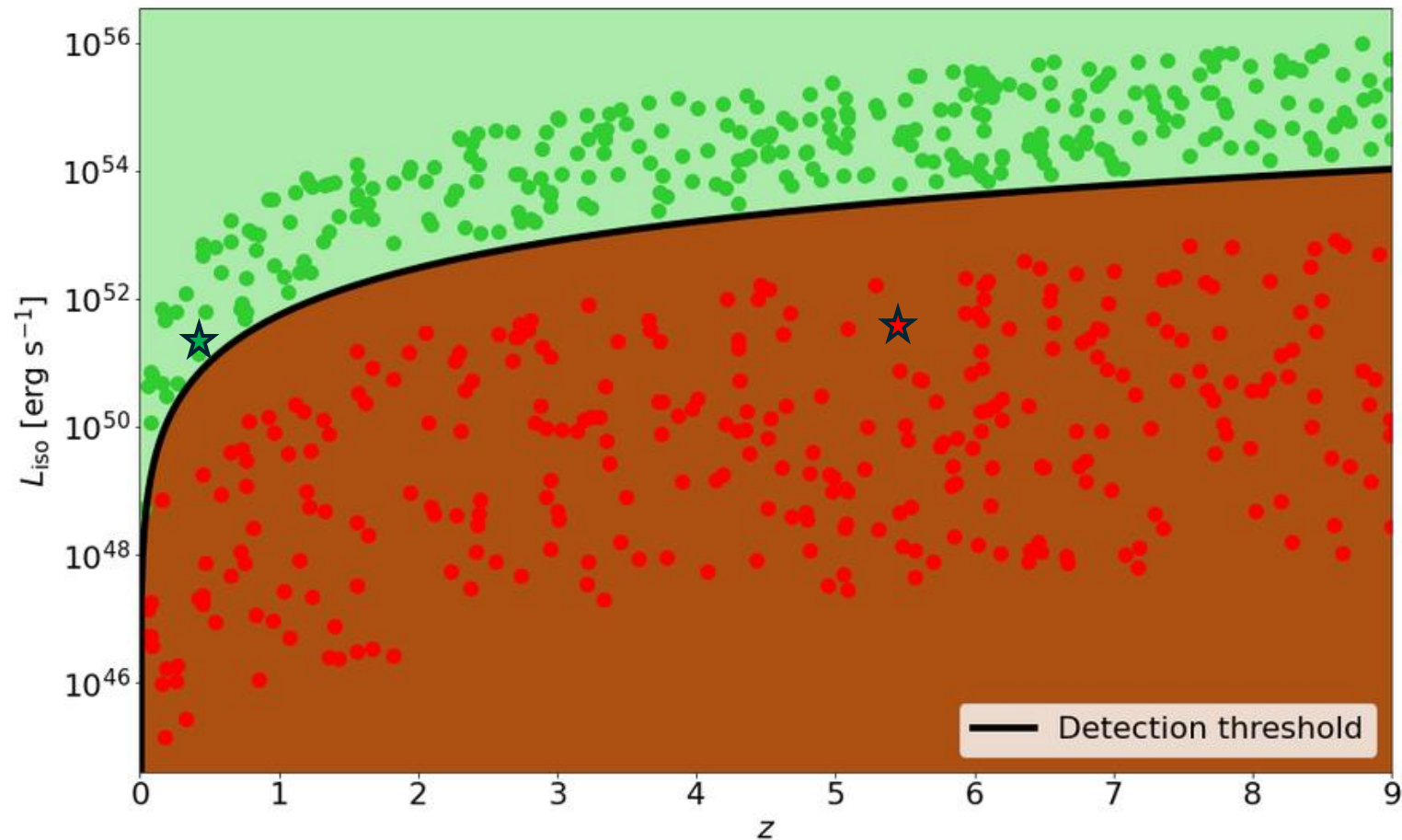

Observed GRBs

Faint GRBs

Real population = Observed + Faint

The **faintest events** can not be seen at large distances.

# Selection effects

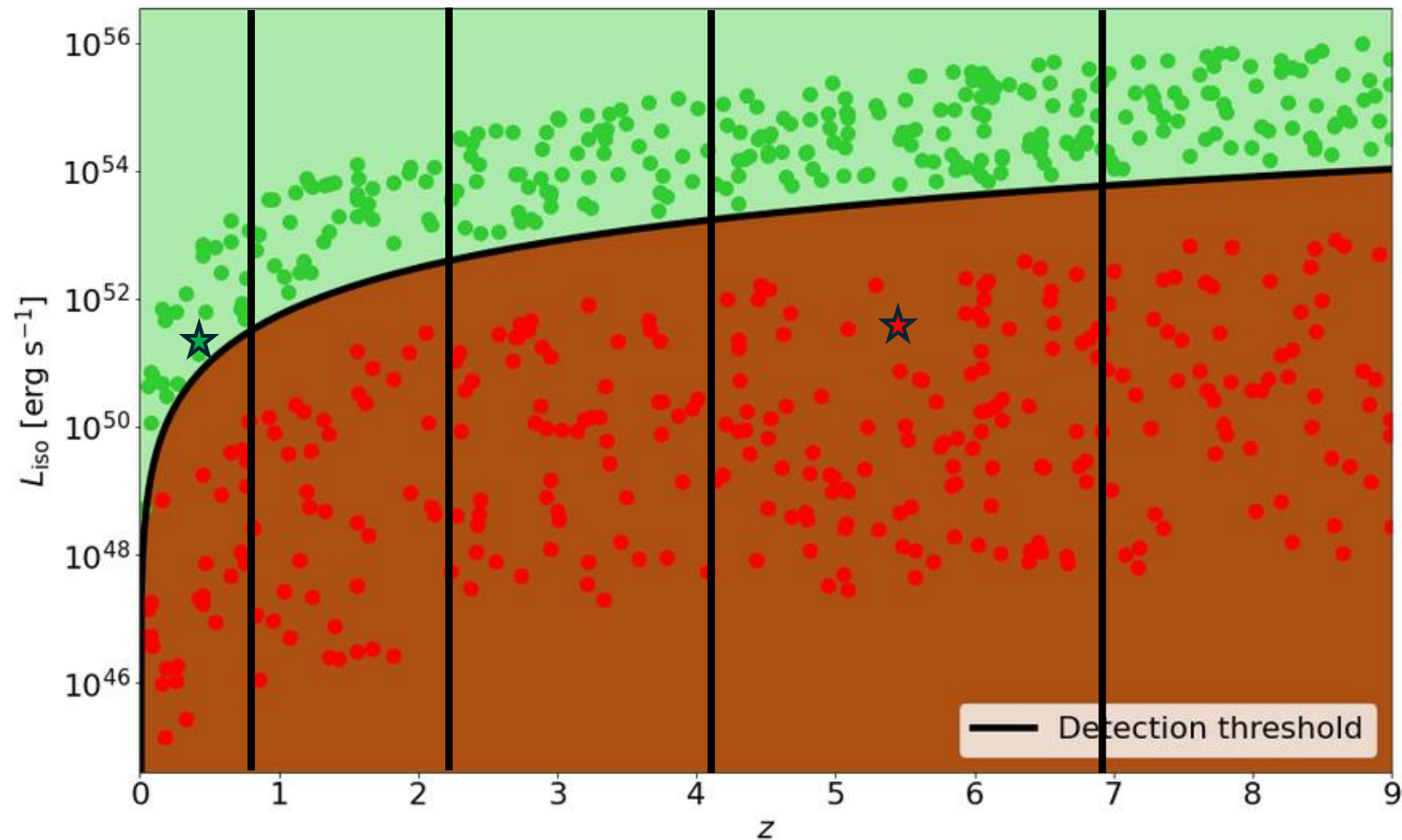

Observed GRBs

Faint GRBs

Real population = Observed + Faint

The **faintest events** can not be seen at large distances.

# Selection effects

 Simulated

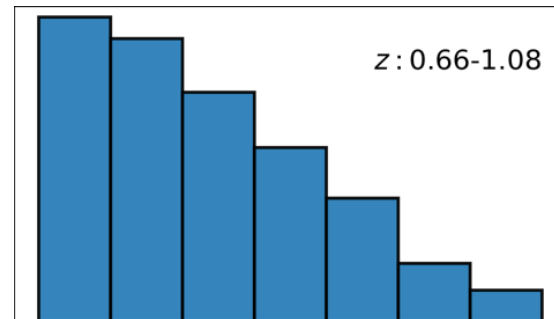

# Selection effects

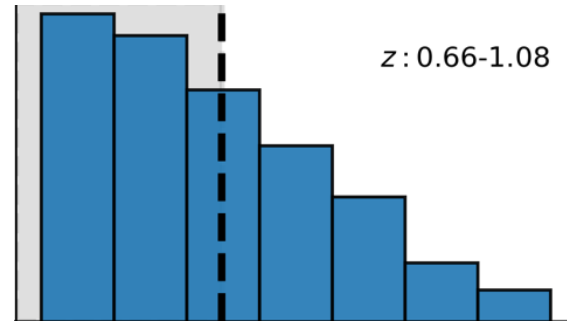

 Simulated

 Detection threshold

# Selection effects

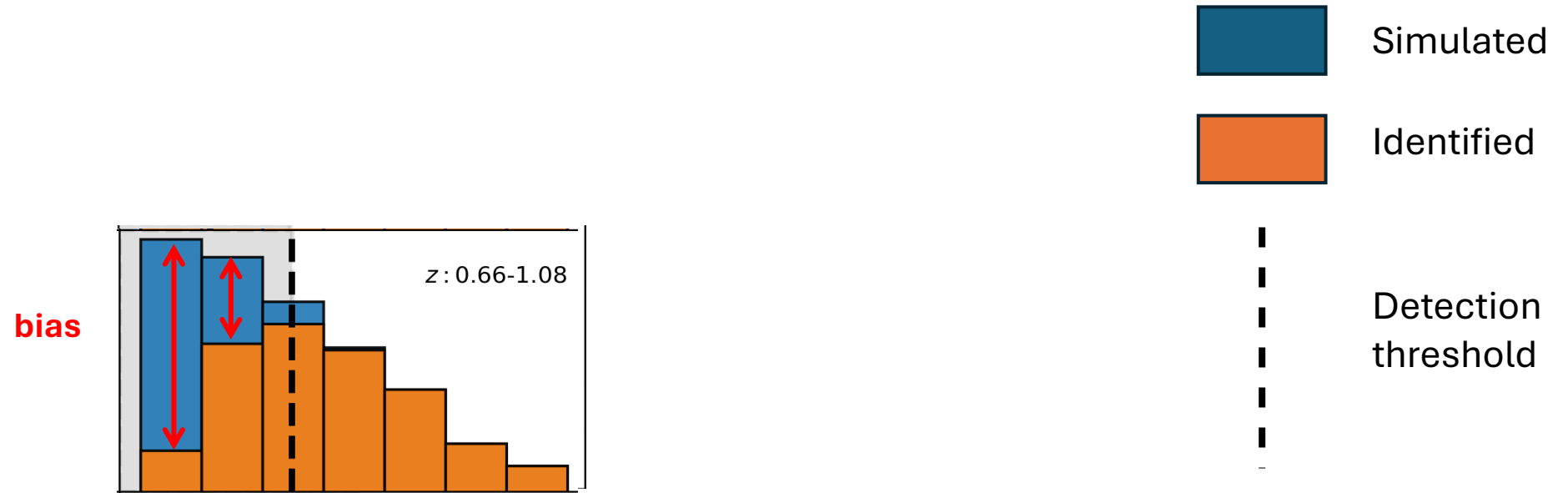

# Selection effects

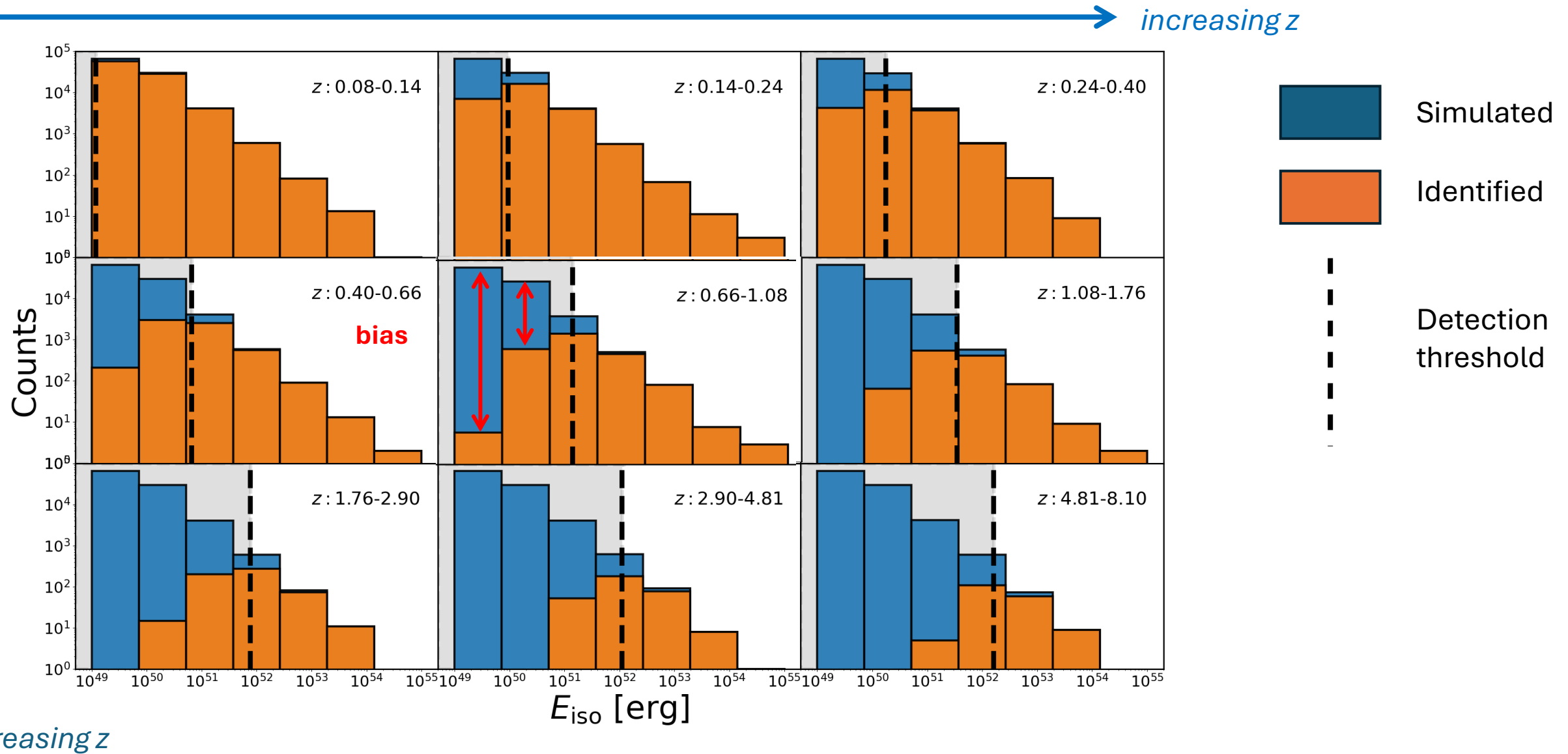

# Results

## ENERGY

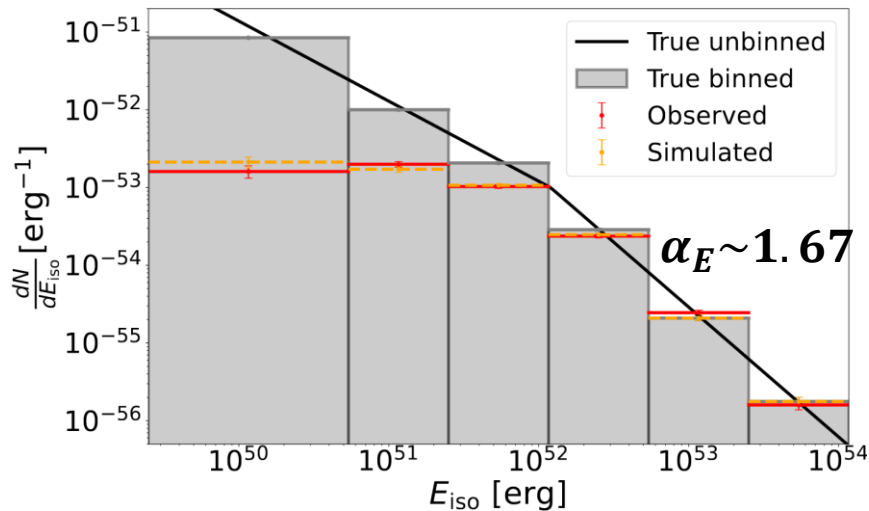
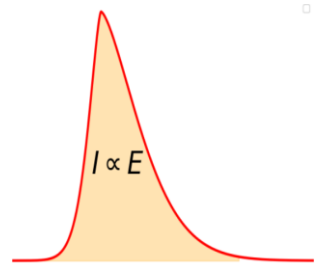

## LUMINOSITY

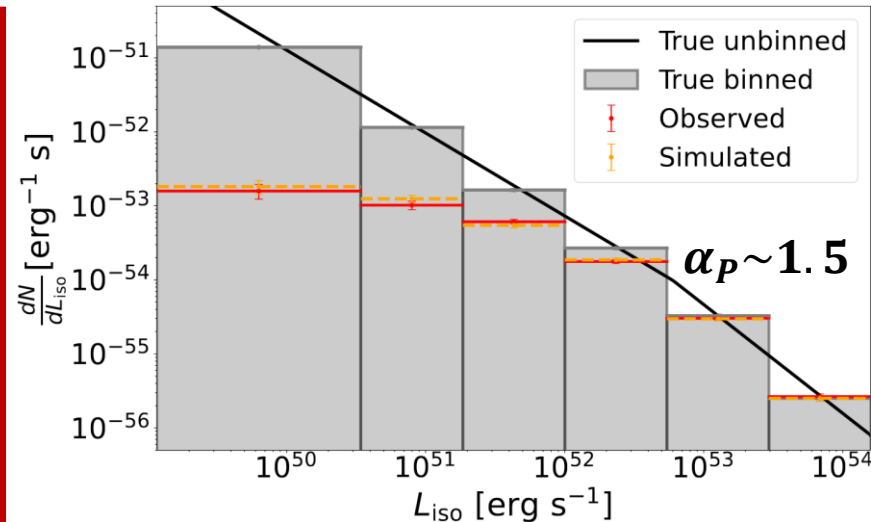
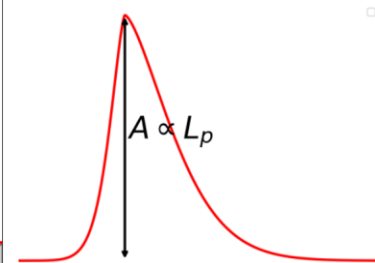

## WAITING TIME

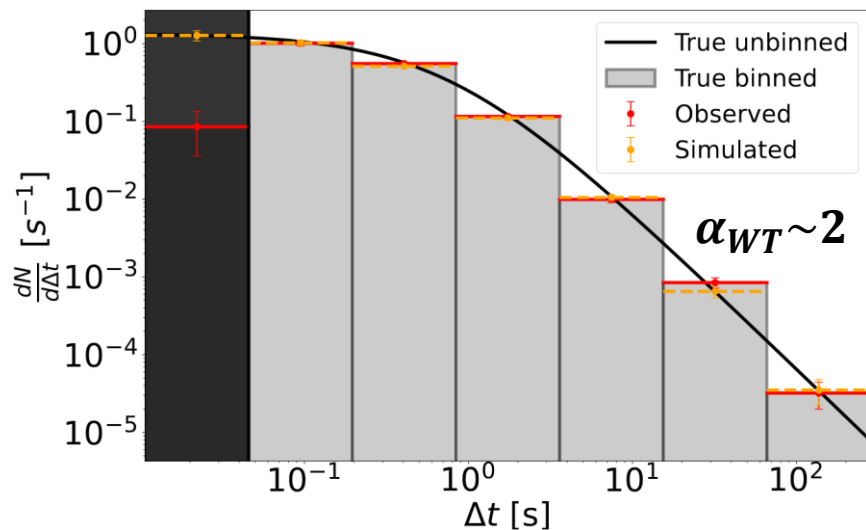
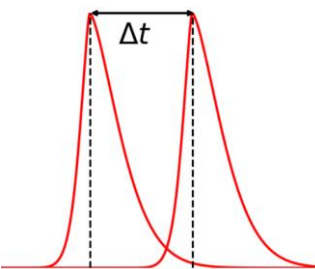

## DURATION

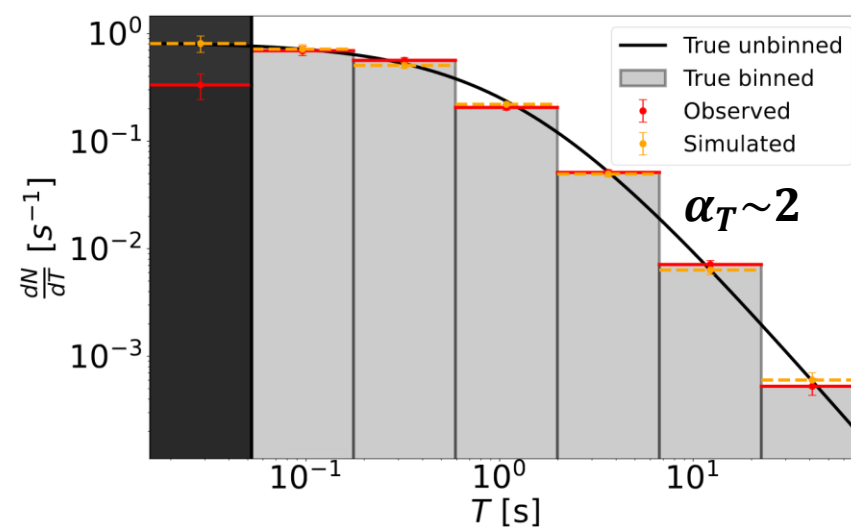
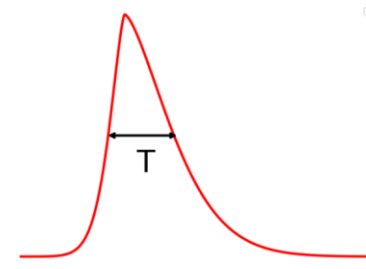

# Results

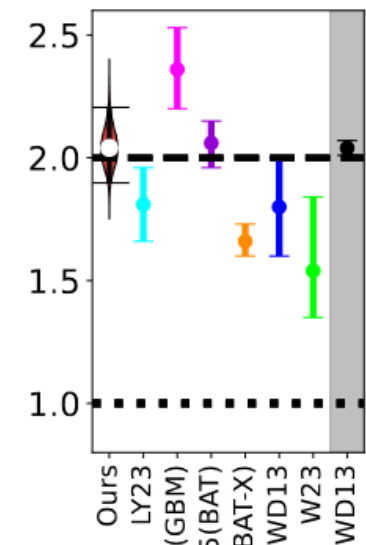
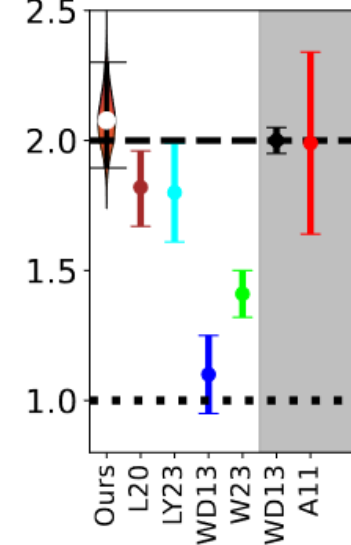
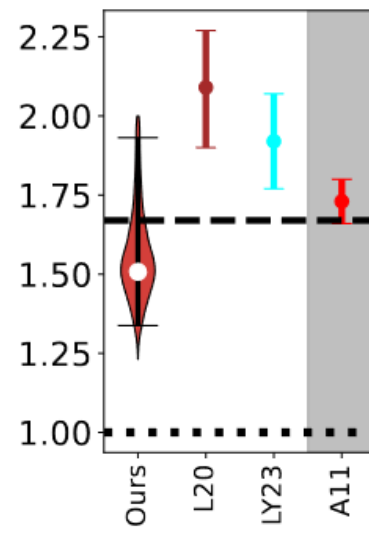
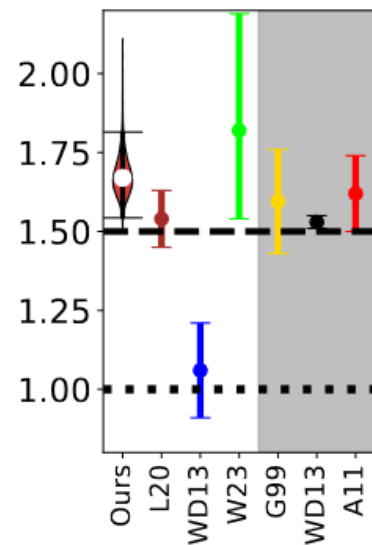
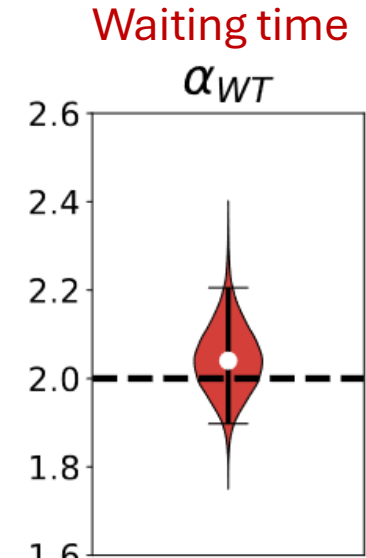
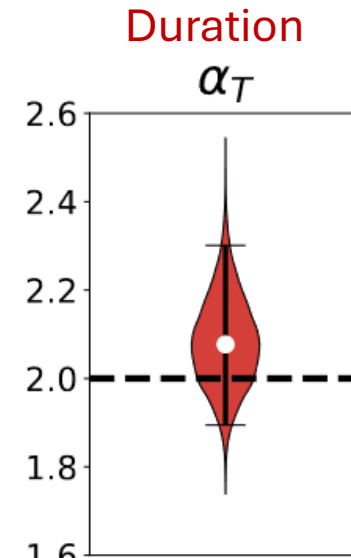
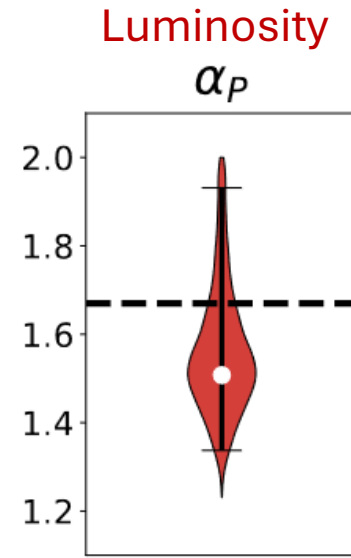
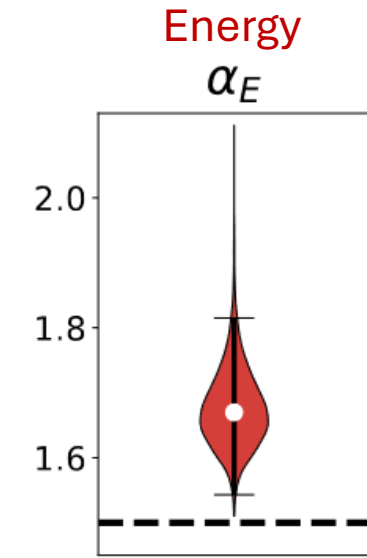
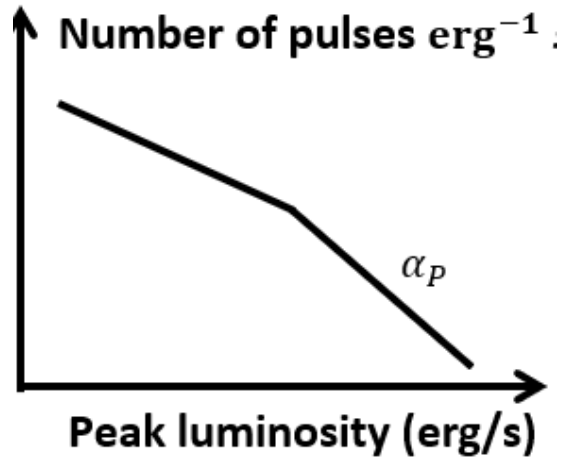
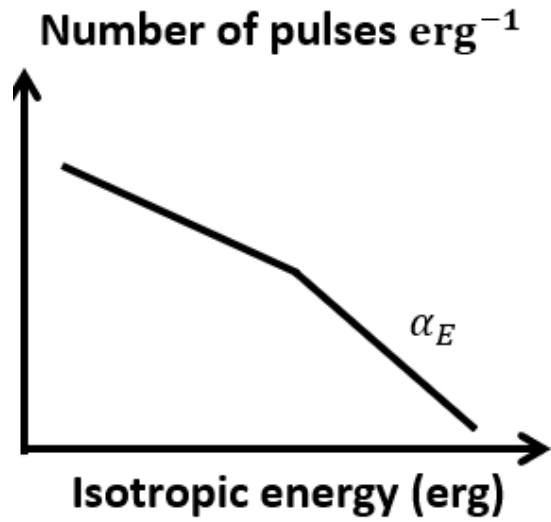

# Interpretation of the results

## ICMART model

(Zhang & Yan, 2011)

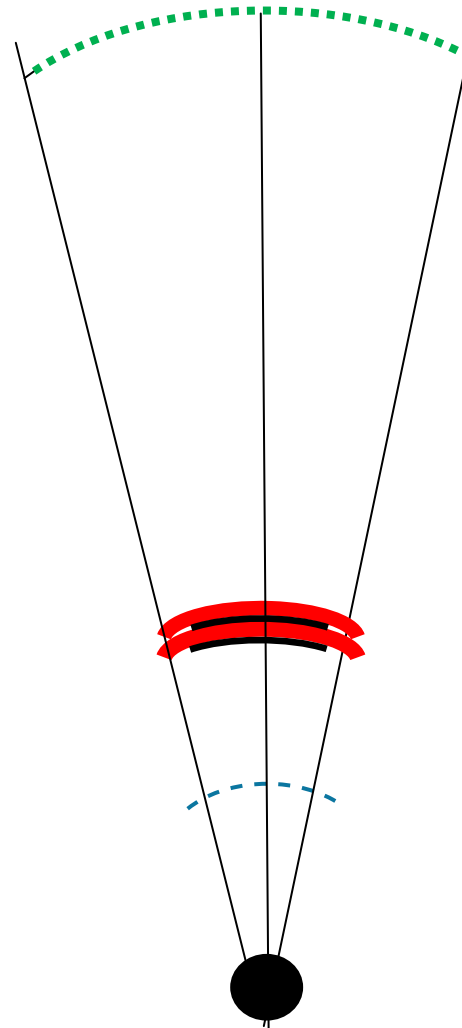

Driver

first shocks

## BTW sand pile model

(Bak et al., 1987)

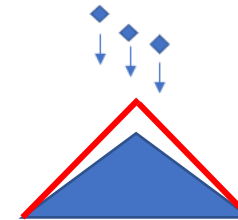

sand grains added

# Interpretation of the results

## ICMART model

(Zhang & Yan, 2011)

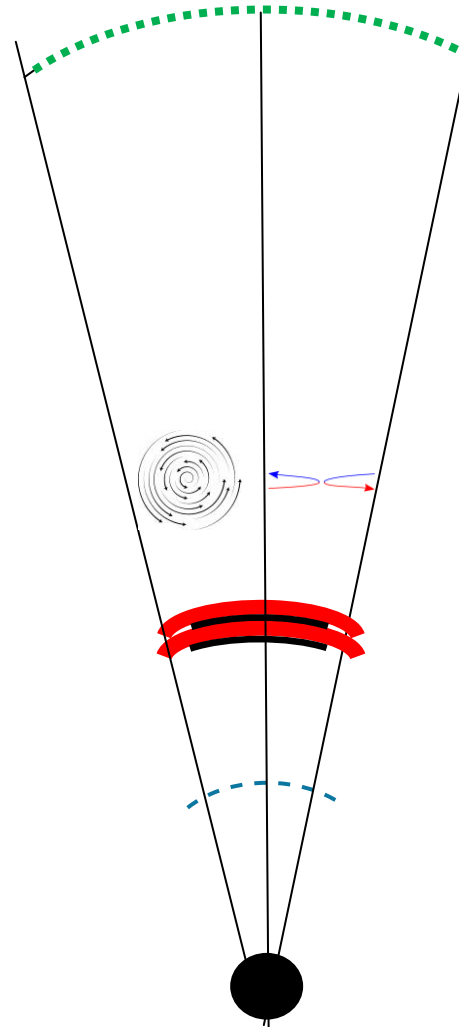

Driver

first shocks

## BTW sand pile model

(Bak et al., 1987)

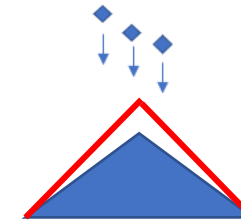

sand grains added

# Interpretation of the results

## ICMART model

(Zhang & Yan, 2011)

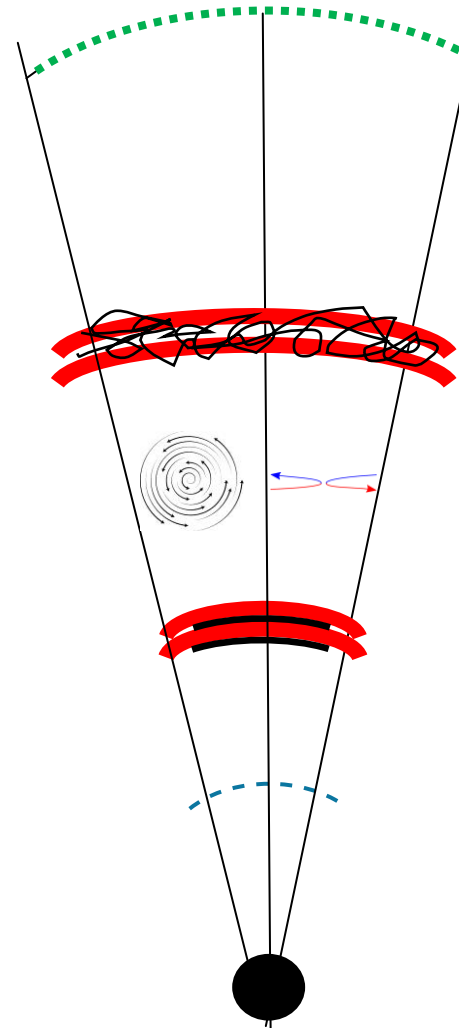

Instability  
threshold

fast magnetic  
reconnection is triggered

Driver

first shocks

## BTW sand pile model

(Bak et al., 1987)

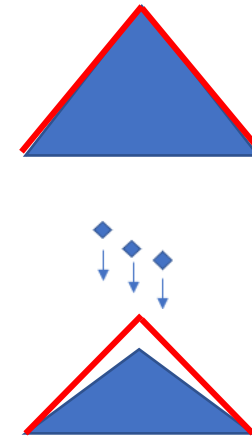

critical slope  
reached

sand grains added

# Interpretation of the results

## ICMART model

(Zhang & Yan, 2011)

Output

magnetic reconnection  
avalanches

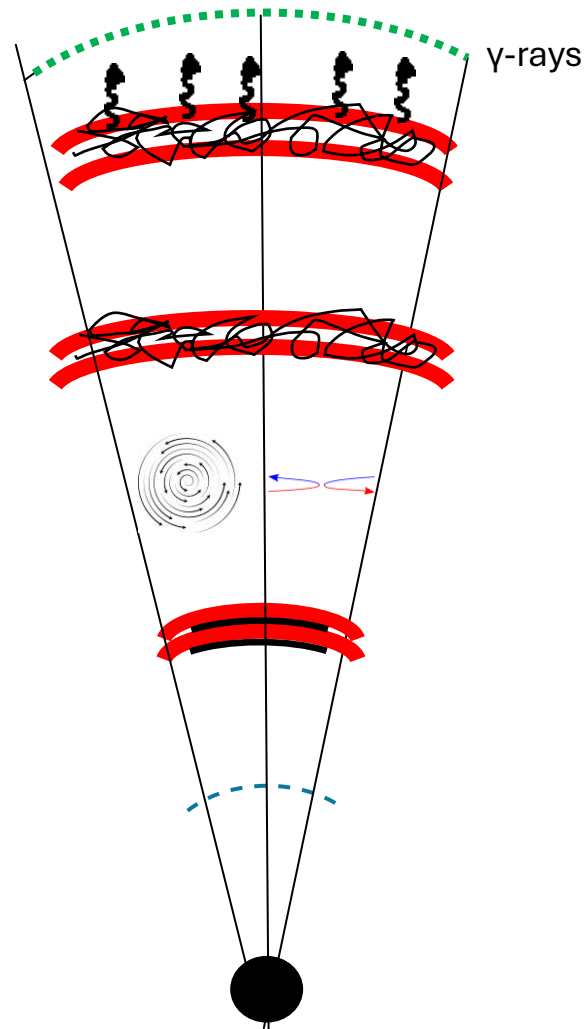

Instability  
threshold

fast magnetic  
reconnection is triggered

Driver

first shocks

## BTW sand pile model

(Bak et al., 1987)

sand pile  
avalanches

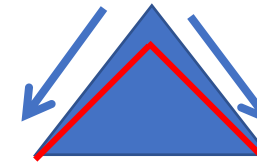

critical slope  
reached

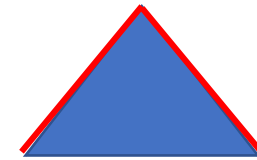

sand grains added

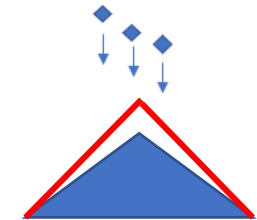

# Conclusions

---

- ➔ **Self Organized Criticality (SOC)** is a model describing the dynamics of systems spontaneously reaching a critical point. It could be helpful to understand **how GRB inner engine release its energy over time**.
- ➔ This is the first study of this kind investigating the presence of SOC in GRBs, **properly taking into account the selection effects**.
- ➔ Our results could be compatible with **prompt emission being the outcome of a dynamical system driven to a 3D SOC state**, even if some deviations (especially the presence of **breaks** in the distributions) are observed.
- ➔ For the first time, **energy and luminosity distribution of the individual pulses** composing the prompt emission is obtained and found to be described by **broken power-laws**:
- ➔ Can the **observed break** be still ascribed to the **selection effects**? Bright GRBs may emit energy in a different way than faint ones.

# Selection effects

We have to perform simulations to determine how **selection effects** are affecting the distribution.

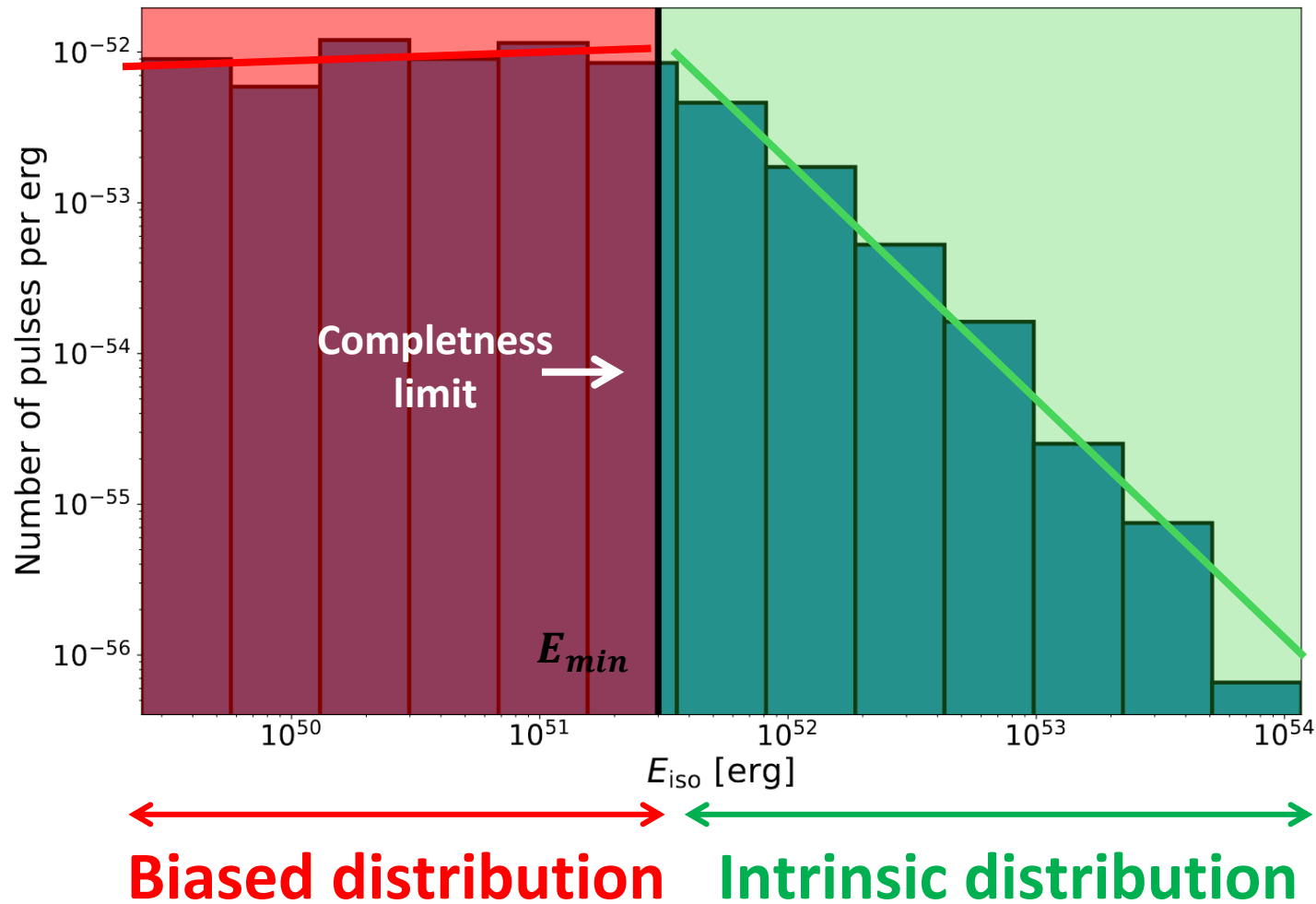

Number of pulses  $\text{erg}^{-1}$

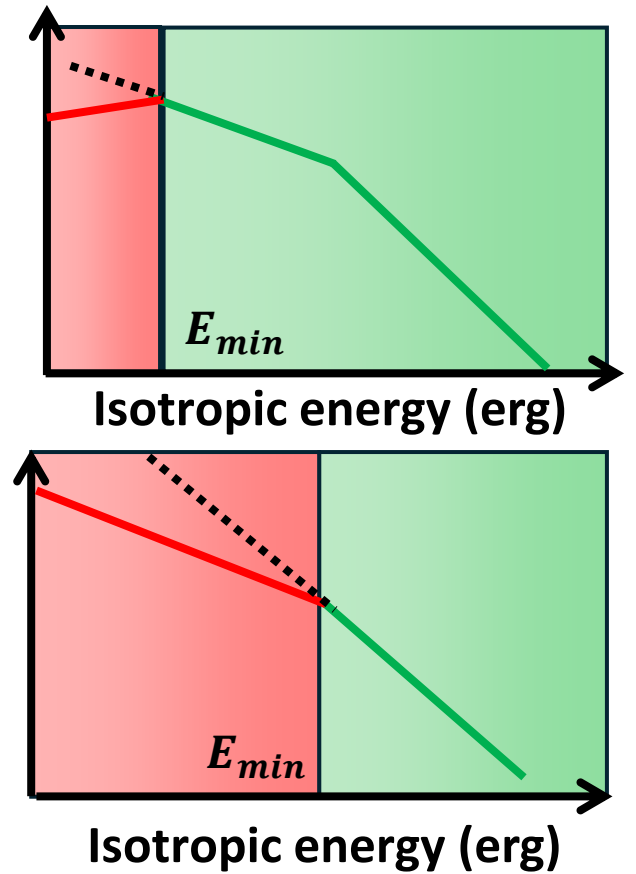

We should do the same for the **peak luminosity** distribution.

For every **simulated pulse** of energy E:

$$u \rightarrow U[0,1]$$

$u < p(E)$  **accepted**

$u > p(E)$  rejected

